



PN 10/16/25/40 - DN 50...200

KAT-A 1912



Product characteristics and benefits

- Resilient seated
- With flange end acc. to EN 1092-2
- Single chamber air valve in compact design
- Very high discharge capacity up to sonic velocity due to stabilised floater
- Triple function air valve
- Venting function:
 - Large orifice to vent high quantities of air during draining the pipeline
 - Large orifice to release high quantities of air during filling the pipeline
 - Small orifice to release low quantities of air during operation under pressure
- Outlet female threaded acc. to DIN ISO 228
- Minimum operation pressure: 0.3 bar
- With sidewise drainage plug

Materials

- Body: Ductile cast iron EN-JS 1030 (GGG-40)
- Bonnet: Ductile cast iron EN-JS 1030 (GGG-40)
- Bonnet bolts: Stainless steel A4 (DIN EN ISO 3506)
- Inner parts: Stainless steel 1.4571
- Float: Stainless steel 1.4571 (exception: DN 50 synthetic)
- Sealing: EPDM

Corrosion protection

- Inside and outside epoxy coating acc. to GSK guidelines

Versions

- Standard version as described
- For pressures of 0.1...1 bar special seal (with special sealing). Please specify operating pressure when inquiring/ordering.
- For flange dimensions acc. to ANSI
- With insect protection
- DN 50/PN 16 connection with 2" thread available on request

Field of Application

- Chamber installation
- Installation in plants

Tests and approvals

- Final inspection test acc. to EN 12266 (DIN 3230 Part 4)

Note

For proper installation and safe operation please follow the installation and operation instructions:

KAT-B 1912

Field of application

DN	PN	Maximum operating pressure [bar]	Maximum operating temperature for neutral liquids [°C]
50...200	40	40	50
50...200	25	25	50
50...200	16	16	50
200	10	10	50

Pressure test acc. to EN 12266

Test pressure body with water [bar]	Test pressure seat with water [bar]
44	44
37.5	37.5
24	24
15	15



Drawing

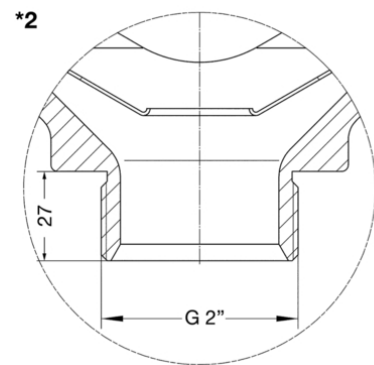
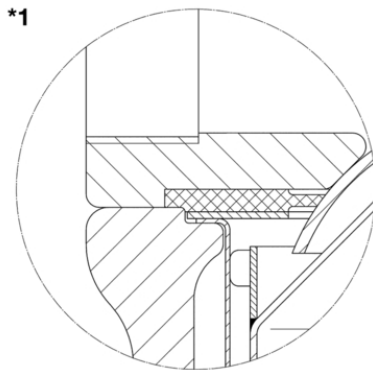
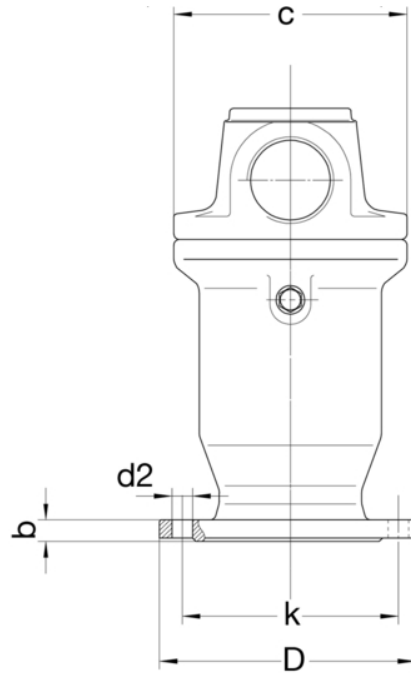
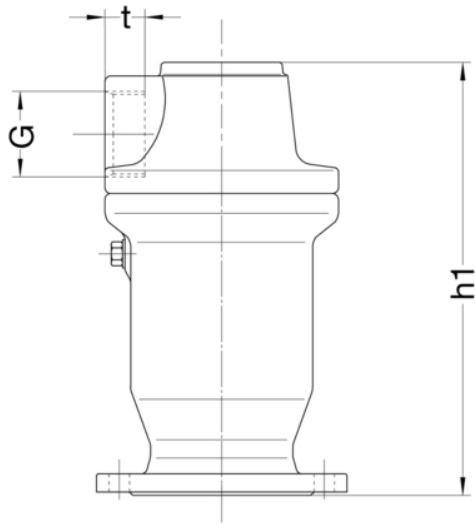

*1: Special seal for operating pressures of 0.1...1 bar (no standard version)

*2: DN 50 / PN 16 connection with G 2" thread (no standard version)

Technical data

PN 40

DN	50	80	100	150	200
G Screw connection [inch]	2"	2"	2 1/2"	4"	4"
D [mm]	165	200	235	300	375
b [mm]	19	19	19	26	30
c [mm]	185	185	205	260	260
d2 [mm]	18	18	22	27	31
h1 [mm]	340	340	380	510	510
k [mm]	125	160	190	250	320
t [mm]	25	25	30	40	40
No. of holes	4	8	8	8	12
Weight approx. [kg]	25.00	25.00	28.00	57.00	58.00
Volume approx. [m ³]	0.015	0.015	0.020	0.040	0.040

VAG DUOJET® Automatic Air Valve

Single-chamber type



Water

Technical data

PN 25

DN		50	80	100	150	200
G Screw connection	[inch]	2"	2"	2 1/2"	4"	4"
D	[mm]	165	200	235	300	360
b	[mm]	19	19	19	20	22
c	[mm]	185	185	205	260	260
d2	[mm]	18	18	22	26	26
h1	[mm]	340	340	380	510	510
k	[mm]	125	160	190	250	310
t	[mm]	25	25	30	40	40
No. of holes		4	8	8	8	12
Weight approx.	[kg]	25.00	25.00	28.00	56.00	57.00
Volume approx.	[m ³]	0.015	0.015	0.020	0.040	0.040

PN 16

DN		50	80	100	150	200
G Screw connection	[inch]	1 1/4"	2"	2 1/2"	4"	4"
D	[mm]	165	200	220	285	340
b	[mm]	19	19	19	19	20
c	[mm]	160	185	205	260	260
d2	[mm]	18	18	18	22	22
h1	[mm]	280	340	380	510	510
k	[mm]	125	160	180	240	295
t	[mm]	20	25	30	40	40
No. of holes		4	8	8	8	12
Weight approx.	[kg]	15.00	25.00	28.00	56.00	57.00
Volume approx.	[m ³]	0.010	0.015	0.020	0.040	0.040

PN 10

DN		200
G Screw connection	[inch]	4"
D	[mm]	340
b	[mm]	20
c	[mm]	260
d2	[mm]	22
h1	[mm]	510
k	[mm]	295
t	[mm]	40
No. of holes		8
Weight approx.	[kg]	57.00
Volume approx.	[m ³]	0.040



Further information

Rate of air release during filling the pipeline
large orifice

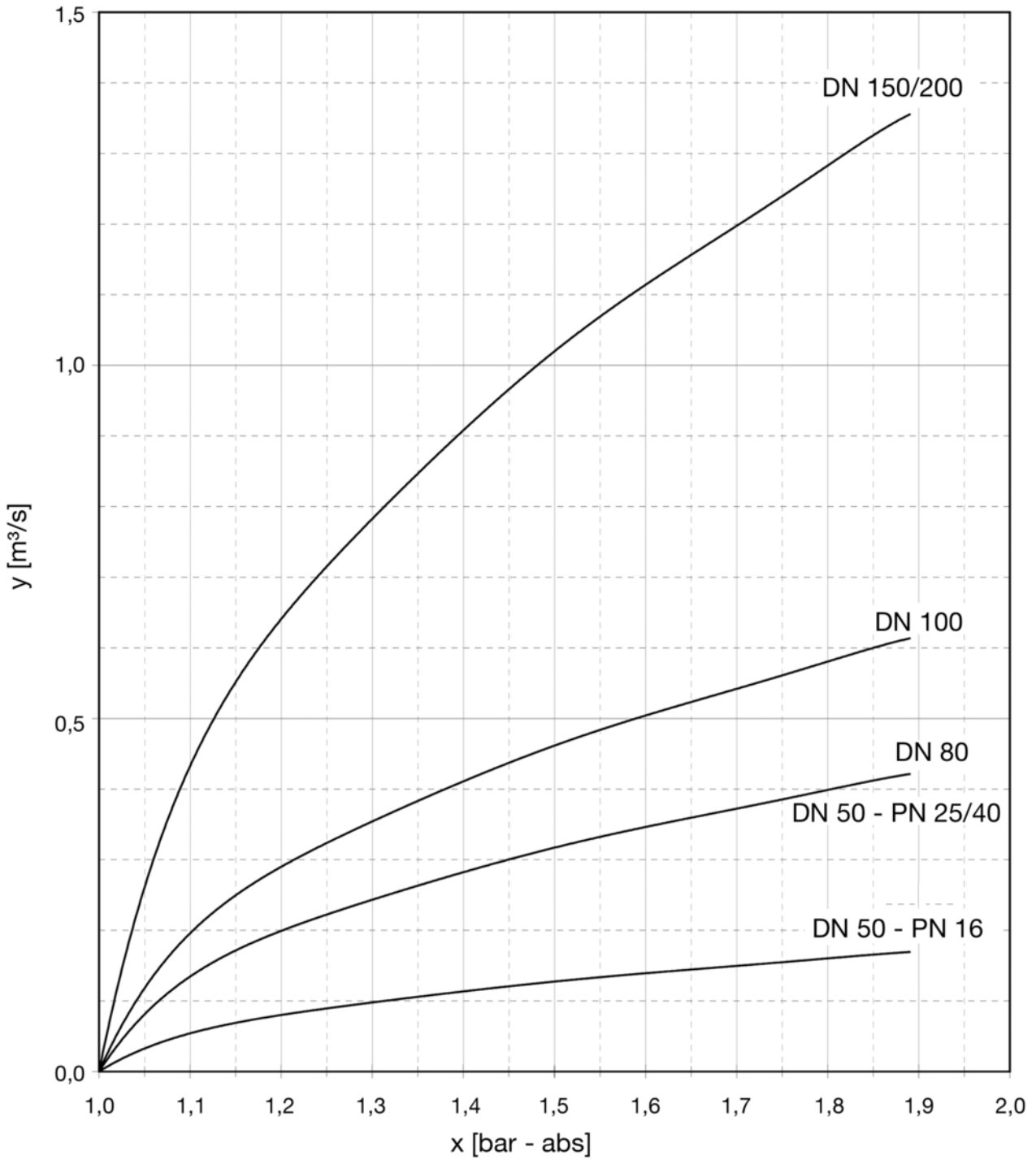

x: Internal pressure p [bar - absolute]
y: Air release rate Q [m^3/s]



Further information

Rate of air intake in dependence of the operating pressure
large orifice

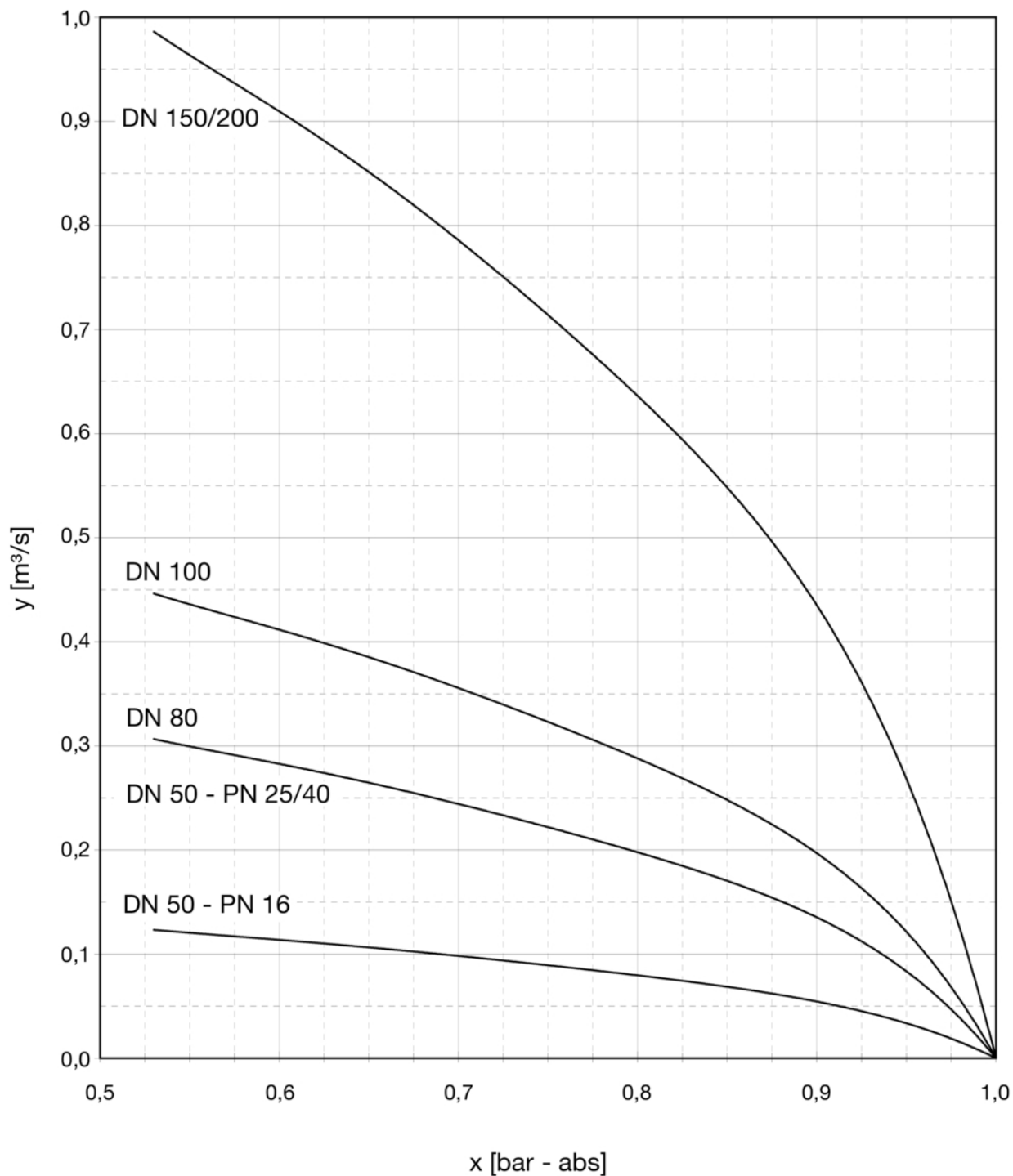

x: Internal pressure p [bar - absolute]
y: Air inflow rate Q [m³/s]



Further information

Rate of air release at full internal operating pressure
small orifice

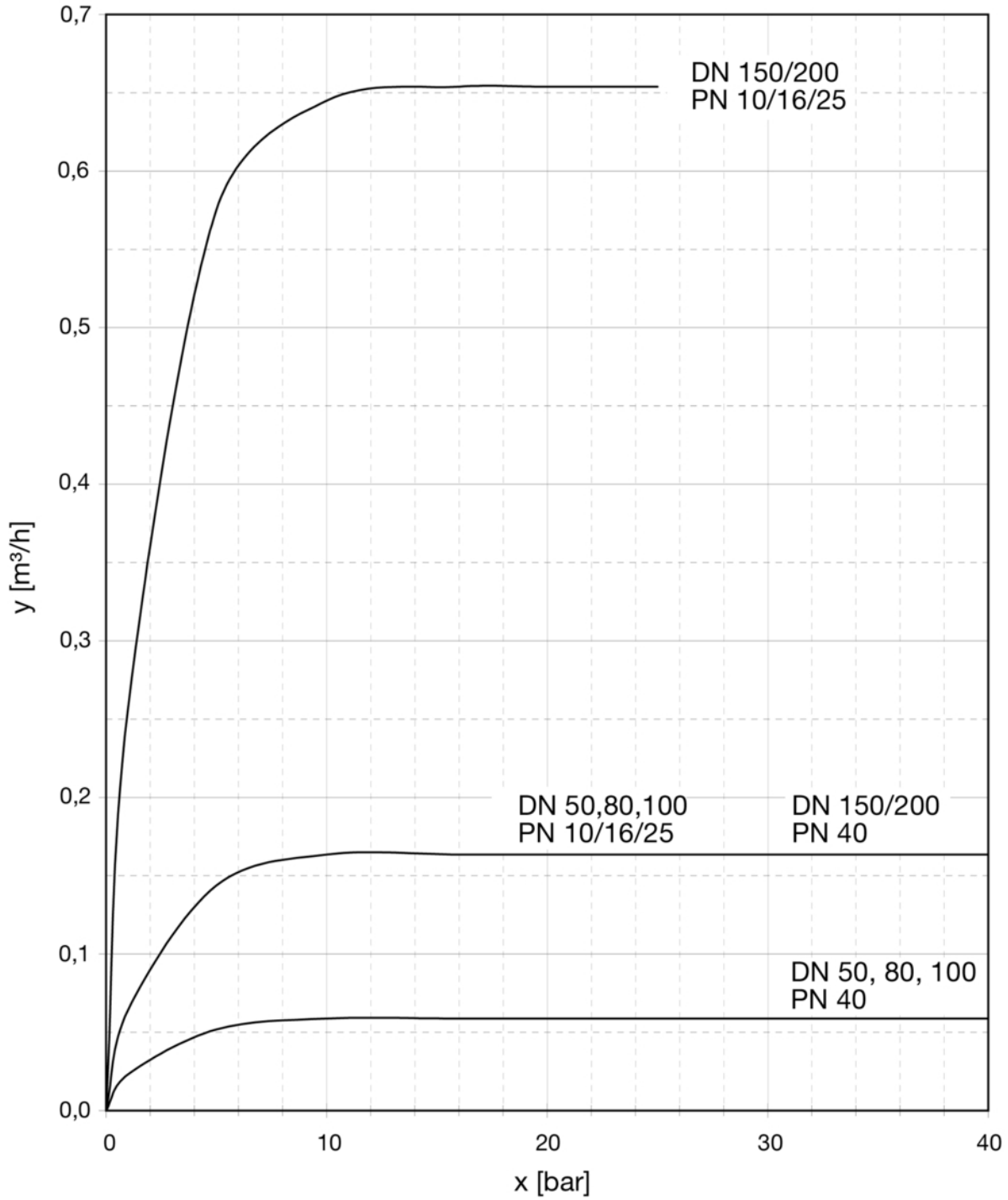

x: Operating pressure p in pipeline [bar]
y: Air release rate Q [m³/h]